

Pull Studs ISO 7388 form B / ISO 7388 B 型拉钉

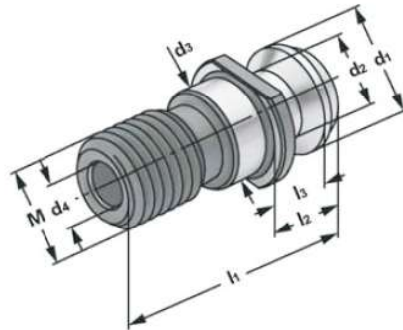

应用范围: 穿孔, 无密封圈, 用于带中心通水的刀柄。

Use: With through hole, without O-ring

Order No. 货号	Size 规格	M	d ₂	d ₃	d ₄	l ₃	l ₁
2047.2000	PS-ISO40-M16-Hole	M16	12.95	17	7	11.15	44.5
2057.2000	PS-ISO50-M24-Hole	M24	19.60	25	11.5	17.95	65.5

应用范围: 穿孔, 带密封圈, 用于带中心通水的刀柄。

Use: With through hole, with O-ring

Order No. 货号	Size 货号	M	d ₂	d ₃	d ₄	l ₃	l ₁
2047.1000	PS-ISO40-M16-O-Hole	M16	12.95	17	7	11.15	44.5
2057.1000	PS-ISO50-M24-O-Hole	M24	19.60	25	11.5	17.95	65.5

Pull studs DIN 2080 without groove / DIN 2080 拉钉

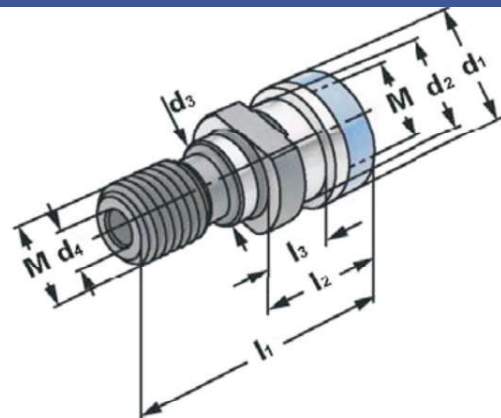

应用范围: 穿孔, 无密封圈, 用于需要中心通水的刀柄。

Use: With through hole, without O-ring

Order No. 货号	Size 规格	M	d ₂	d ₃	d ₄	l ₃	l ₁
2043.2000	PS-DIN2080-M16-Hole	M16	21.1	17	7	13.6	53
2053.2000	PS-DIN2080-M24-Hole	M24	32	25	7	13.3	65.1