

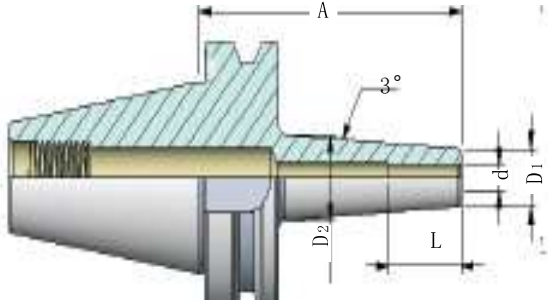













Schrik with 3° / BT 3° 热缩刀柄



G2.5 25,000min⁻¹

4xd ↗ ≤ 0.003

BT- 3° 热缩刀柄

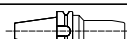
Order No. 货号	Size 规格	d 夹持直径	D ₁	D ₂	L	Cooling 冷却方式	A 有效长度	
31.8103.80	BT30-SF3-80	3	9	14.8	9	AD	80	
31.8104.80	BT30-SF4-80	4	10	15.8	12	AD		
31.8105.80	BT30-SF5-80	5	11	16.8	15	AD		
31.8106.80	BT30-SF6-80	6	12	17.8	25	AD		
31.8108.80	BT30-SF8-80	8	14	19.8		AD		
31.8108.120	BT30-SF8-120				AD	120		
31.8110.80	BT30-SF10-80	10	16	21.8	32	AD	80	
31.8110.120	BT30-SF10-120					AD	120	
31.8112.80	BT30-SF12-80	12	18	23.8	38	AD	80	
31.8112.120	BT30-SF12-120					AD	120	
31.8114.80	BT30-SF14-80	14	20	25.8	40	AD	80	
31.8114.120	BT30-SF14-120					AD	120	
31.8116.90	BT30-SF16-90	16	22	27.8		AD	90	
31.8116.120	BT30-SF16-120					AD	120	
31.8118.90	BT30-SF18-90	18	24	29.8	42	AD	90	
31.8118.120	BT30-SF18-120					AD	120	
31.8120.90	BT30-SF20-90	20	26	31.8	44	AD	90	
31.8120.120	BT30-SF20-120					AD	120	



TOOL HOLDER / 刀柄 MAS 403 BT

Shrink with 3° / BT 3° 热缩刀柄

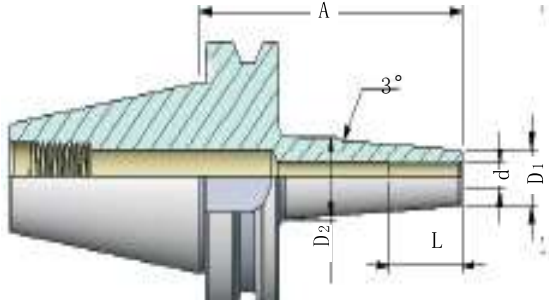

G2.5 25,000min⁻¹

4xd ↗ ≤ 0.003

BT-3° 热缩刀柄

Order No. 货号	Size 规格	d 夹持直径	D ₁	D ₂	L	Cooling 冷却方式	A 有效长度		
41.8103.90	BT40-SF3-90	3	9	17	9	AD	90		
41.8104.90	BT40-SF4-90	4	10	18	12	AD			
41.8105.90	BT40-SF5-90	5	11	19	15	AD			
41.8106.90	BT40-SF6-90	6	12	20	25	AD	90		
41.8106.120	BT40-SF6-120					AD	120		
41.8108.90	BT40-SF8-90	8	14	22		AD	90		
41.8108.120	BT40-SF8-120					AD	120		
41.8110.90	BT40-SF10-90	10	16	24	32	AD	90		
41.8110.120	BT40-SF10-120					AD	120		
41.8112.90	BT40-SF12-90	12	18	26		38	AD	90	
41.8112.120	BT40-SF12-120						AD	120	
41.8114.90	BT40-SF14-90	14	20	28	40		AD	90	
41.8114.120	BT40-SF14-120						AD	120	
41.8116.90	BT40-SF16-90	16	22	30		40	AD	90	
41.8116.120	BT40-SF16-120						AD	120	
41.8118.95	BT40-SF18-95	18	24	32	42		AD	95	
41.8118.120	BT40-SF18-120						AD	120	
41.8120.95	BT40-SF20-95	20	26	34		44	AD	95	
41.8120.120	BT40-SF20-120						AD	120	

MAS 403 BT



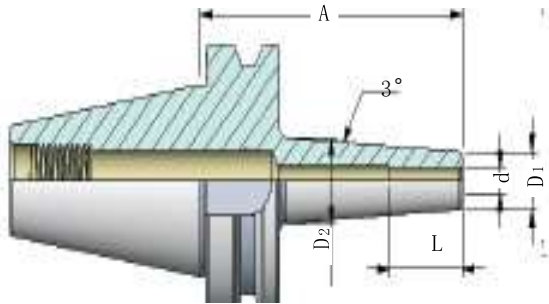







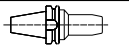

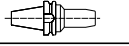

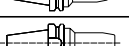

Schrik with 3° / BT 3° 热缩刀柄

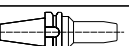
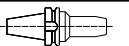
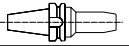
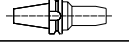

G2.5 25,000min⁻¹

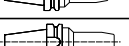
4xd ↗ ≤ 0.003

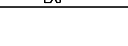
BT-3° 热缩刀柄

Order No. 货号	Size 规格	d 夹持直径	D ₁	D ₂	L	Cooling 冷却方式	A 有效长度	
41.8125.100	BT40-SF25-100	25	31	39	50	AD	100	
41.8125.120	BT40-SF25-120					AD	120	
51.8106.100	BT50-SF6-90	6	12	20.4	25	AD	100	
51.8106.150	BT50-SF6-120					AD	150	
51.8108.100	BT50-SF8-90	8	14	22.4	25	AD	100	
51.8108.150	BT50-SF8-120					AD	150	
51.8110.100	BT50-SF10-90	10	16	24.4	32	AD	100	
51.8110.150	BT50-SF10-120					AD	150	
51.8112.100	BT50-SF12-90	12	18	26.4	38	AD	100	
51.8112.150	BT50-SF12-120					AD	150	
51.8114.100	BT50-SF14-90	14	20	28.4	40	AD	100	
51.8114.150	BT50-SF14-120					AD	150	
51.8116.100	BT50-SF16-90	16	22	30.4	40	AD	100	
51.8116.150	BT50-SF16-120					AD	150	
51.8118.100	BT50-SF18-95	18	24	32.4	42	AD	100	
51.8118.150	BT50-SF18-120					AD	150	
51.8120.100	BT50-SF20-95	20	26	34.4	44	AD	100	
51.8120.150	BT50-SF20-120					AD	150	
51.8125.100	BT50-SF25-100	25	31	39.4	50	AD	100	



BT50 Shrink with 3° / BT 3° 热缩刀柄

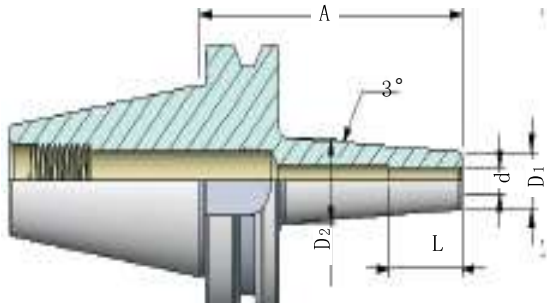

MAS 403 BT

G2.5 25,000min⁻¹

4xd ≤ 0.003

BT-3° 热缩刀柄

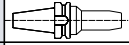
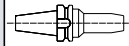
Order No. 货号	Size 规格	d 夹持直径	D ₁	D ₂	L	Cooling 冷却方式	A 有效长度
51.8125.150	BT50-SF25-150	25	31	39.4	50	AD	150 
51.8132.150	BT50-SF32-150	32	38	46.4		AD	150 

应用范围: 适用于夹持高速钢HSS和硬质合金圆柱柄刀具。
直径为Ø3,Ø4和Ø5的被夹持刀具的柄部公差要求达到h4,直径为Ø6~Ø32的被夹持柄部公差要求达到h6
装夹迅速,夹紧力大,高速切削。

相关配件: 拉钉、延长杆

Use: For mounting straight-shank tools
Note: Toolholders suitable for induction-, contact- and hot air shrink units.
Ø3,4,5 with h4-tolerance and Ø6-Ø32 with h6-tolerance

Accessories: rivet, Extension Chuck

